

# FACILITY REQUIREMENTS

Mercury Corner and Command

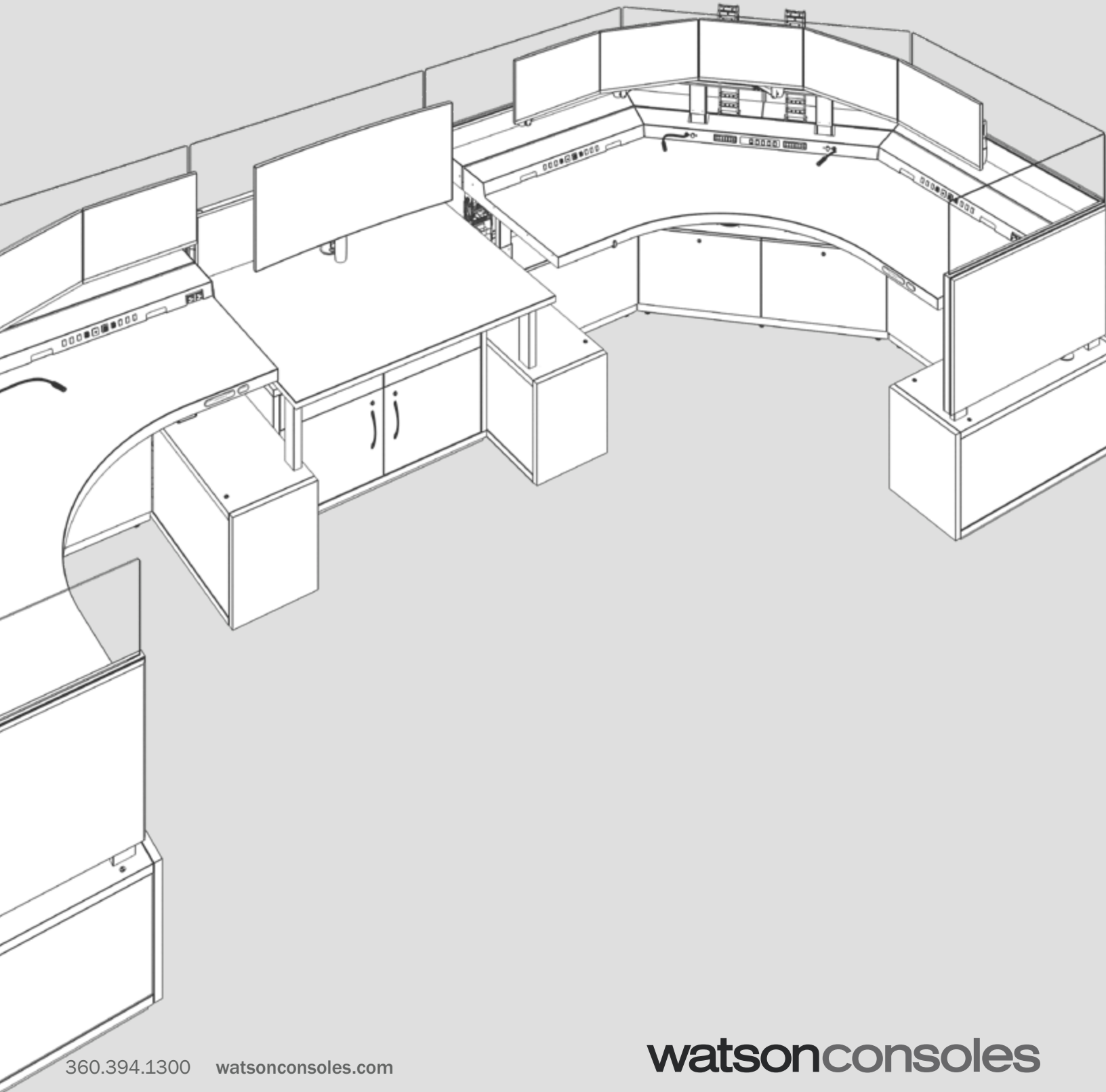

# **FACILITY REQUIREMENTS**

## Mercury Corner and Command

CONSOLE POWER REQUIREMENTS	3
USER POWER RECOMMENDATION	4
TECHNOLOGY LOCATION TYPICAL	5
HUB CUTOUT LOCATIONS	6
CONNECTION TO BUILDING POWER	7

# CONSOLE POWER REQUIREMENTS

## Building Power Connection

Watson Consoles are connected either to NEMA 20R outlets located beneath the raised floor, on the wall, or by running conduit into the console and mounting junction boxes inside the console Hubs. There are dedicated cut-out locations in each console Hub and available mounting locations for junction boxes.

## Lifting System

The console requires 120 VAC, 13.3A, 60Hz. The maximum weight capacity is 200 lbs which includes the monitors.

## Total Console Power Requirements

Total system draw for a console with all environment and ergonomic features in simultaneous operation requires 13.3 amps at 120 VAC. This is a maximum draw for all components operating at full capacity. This includes the Environmental Control system which consumes 50-60 Hz at 120 VAC. Total Environmental Control System power draw during simultaneous operation at maximum load is 7 amps at 120 VAC. The Mercury console is listed per UL 962 Standard for Household and Commercial Furnishings.

## Technology Storage Unit Power Requirements

The Technology Storage unit includes integrated cooling fans which will add to the Total Console Power draw. The number of fans vary by storage type and quantity and will be determined by the final furniture configuration. Each fan adds an additional 80mA, with total power draw of 360mA for the largest furnishing. Typical layout allows power connection to a Power Distribution Unit (PDU) found in the adjacent Hub unit.

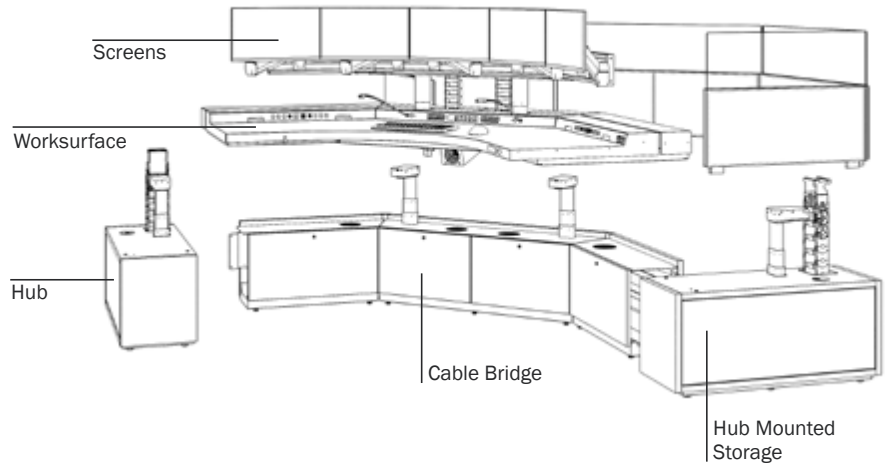

### Cooling Fans —

- Electrical
  - 12 VDC rated voltage
  - 285 mA rated current
  - 3.4 W rated power consumption
  - 10-70 °C operating temperature
- Performance
  - 2700 RPM rated speed
  - 97 CFM airflow
  - 40.5 dB(A) acoustic noise

### Task Lighting —

- Electrical
  - 12 VDC rated voltage
  - 135 mA rated current
  - 135 mA approx. draw

### Ambient Lighting —

- Electrical
  - 12 VDC rated voltage
  - 180 mA rated current
  - 2.16 W / 180 mA power consumption

### Personal Heater —

- Electrical
  - 120 VAC rated voltage
  - 400 W power consumption

# USER POWER RECOMMENDATION

## Building Power Connection

Each console requires a minimum of two dedicated 20A circuits. One for Watson Console functions and a minimum of one for connection of the Power Distribution Units (PDUs). Two PDUs per console are provided. The number of circuits will vary based on end user requirements.



## Power Distribution Unit —

### Output

50/60 Hz compatibility  
Nominal output voltage  
100-122V nominal, single phase  
20A overload protection  
(13) NEMA 5-15/20R

### Physical

1.75"(1U) x17.5"x4.5" /  
IU Rackmount  
Sheet metal construction  
30.2mm outlets (center-center)

### Input

PDU input voltage 100V;  
120V; 127V  
20 amp maximum input  
NEMA 5-20P  
15 ft. input cord  
120 VAC compatibility  
Phase single-phase

### Special Features

TVSS grounding back panel nut  
and bolt grounding lug



## Circuits

Minimum of 6 facility power outlets required (depends on number of circuits specified):

Watson Console Power Requirements:

- 1 Outlet: Under surface PDU for Console lift legs and environmental controls (lights, fans, heater)
- 1 Outlet: In-Dash Power (if optioned/ordered, 2 outlets each)

Mission Critical Equipment Power Requirements:

- 2 Outlets: Hub PDU's (12 outlets each)
- 2 Outlets: In-Dash Monitor power strips  
- *These cannot be plugged into the PDU's as this will not meet code (considered a daisy chain)*

Both hub PDUs can be connected to a single circuit if the customer chooses. The number of circuits at the console is at the discretion of the customer.

## 5-20R DUPLEX / 20A/125V SINGLE PHASE

**Circuit 1:** Non-UPS  
Watson Console Power

**Circuit 2:** UPS Mission Critical  
Equipment Power

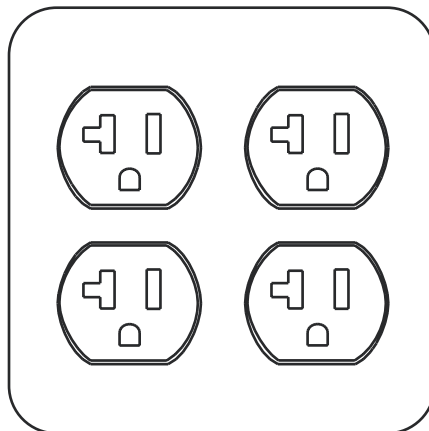
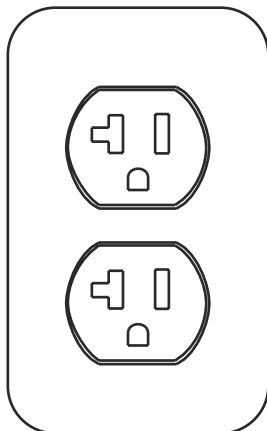

\*This diagram represents the minimum requirements.

# TECHNOLOGY LOCATION TYPICAL

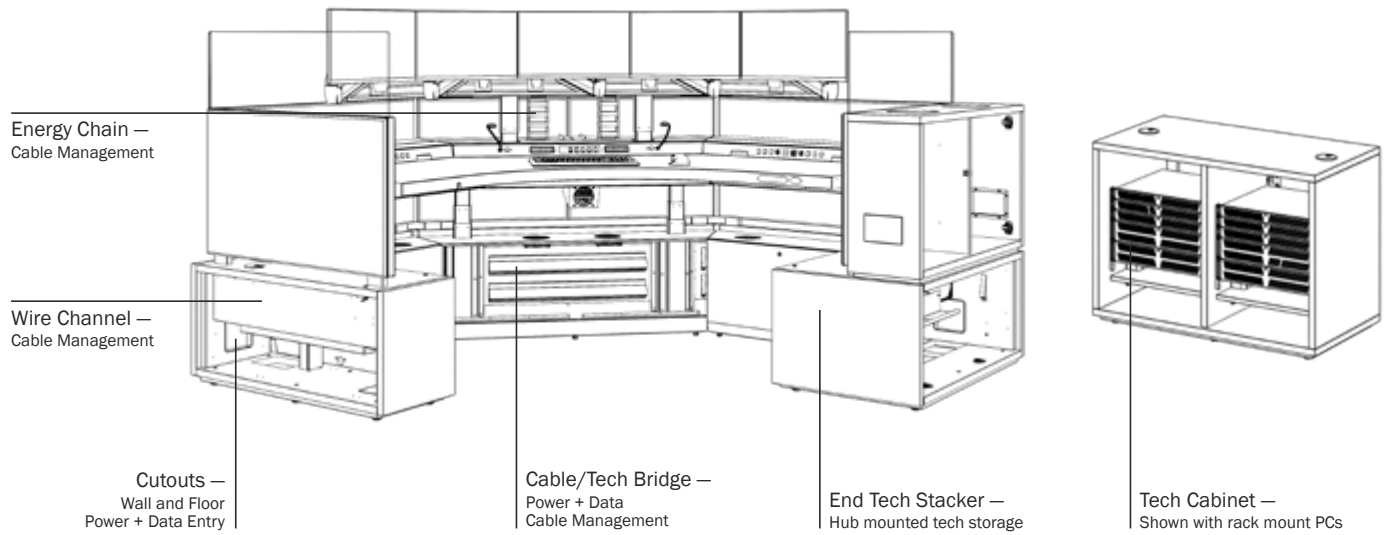

Back of Console

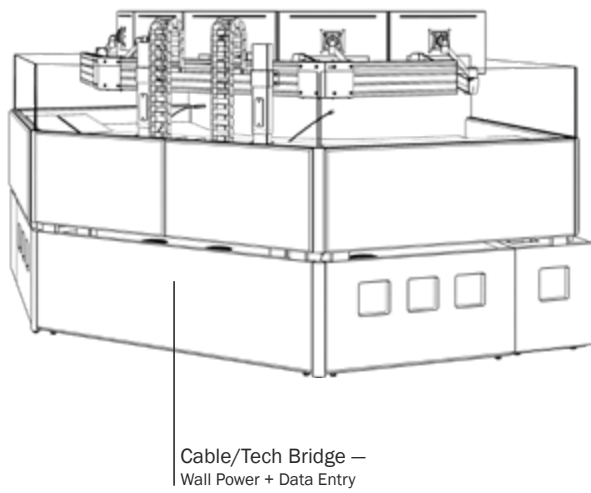

# HUB CUTOUT LOCATIONS

Facility connection is dependent on specification. Mercury consoles are designed to accommodate facility power from wall and/or floor outlets. Facility power must only be routed through the hub cutouts shown.

## 15D x 39W Hub

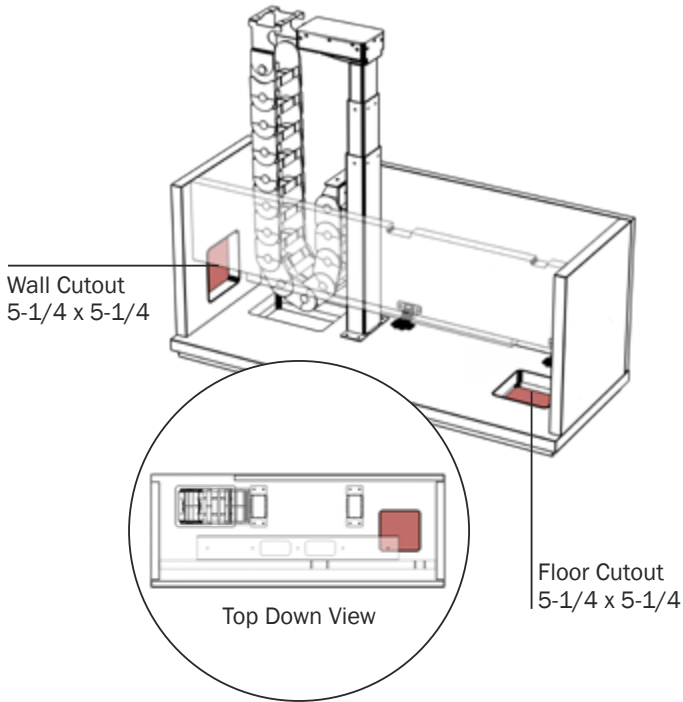

## 24D x 39W Hub

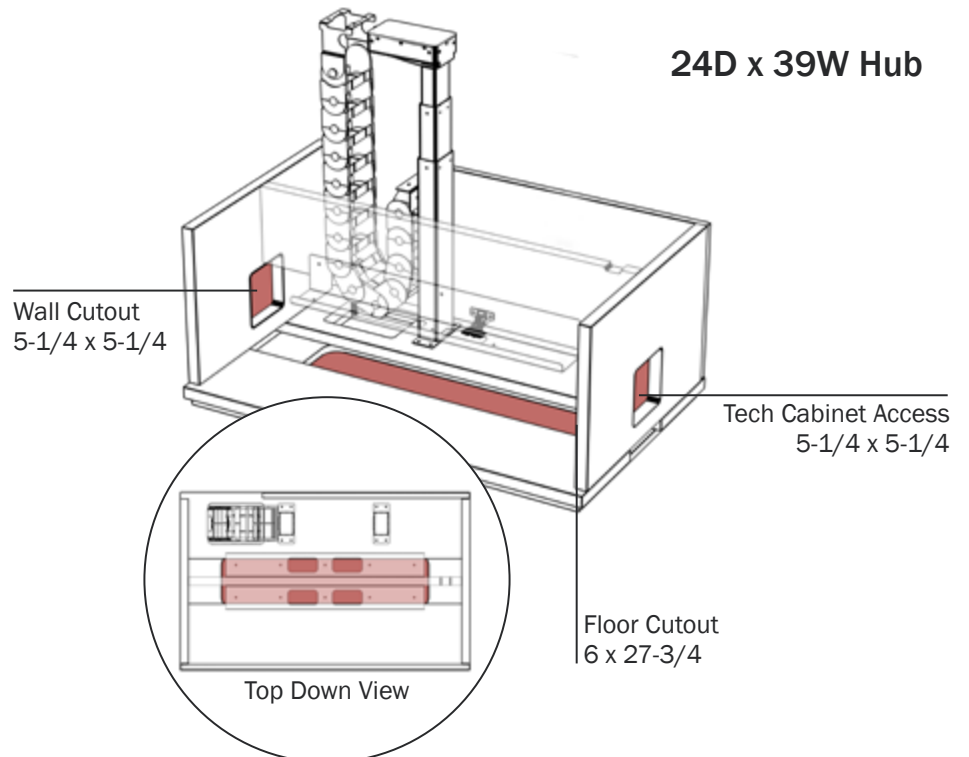

# CONNECTION TO BUILDING POWER

## Integrate Mercury and Facility Power

The illustrations below show examples of Mercury integrated with facility provided power and accessories. Power can also be fed from the ceiling via power poles or from the wall via the Tech/Cable Bridge (not pictured).

### Option 1

Run flexible conduit from raised floor or wall into the console and terminate in a quad-receptacle junction box. Mounting locations for junction boxes are provided in the console (shown below).

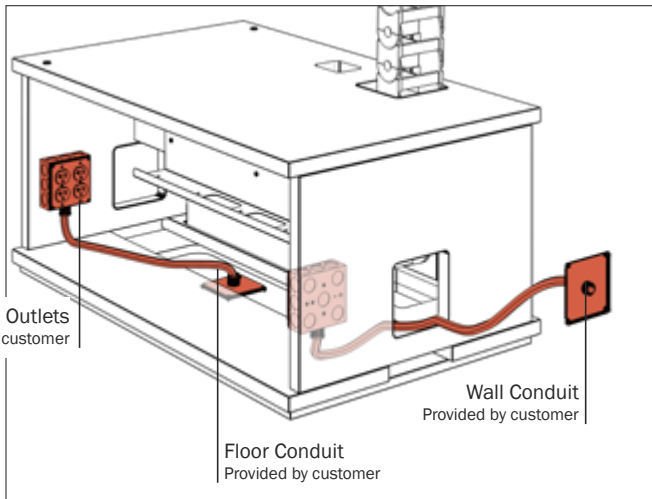

### Option 2

Connect the main power cord directly to 20A wall or floor outlets. If possible, position facility outlets to align with console power access points. If 20A outlets are not available, contact Watson Consoles.

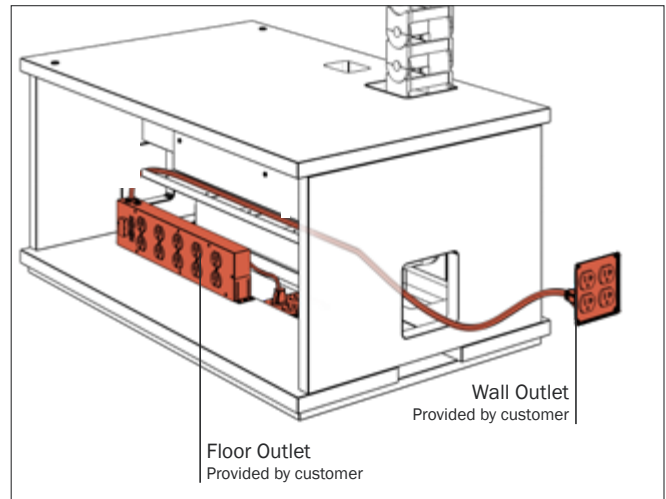

## Power Distribution Units (PDUs)

PDUs are connected to mission critical building power. Ground lug is provided for connection into building grounding system.

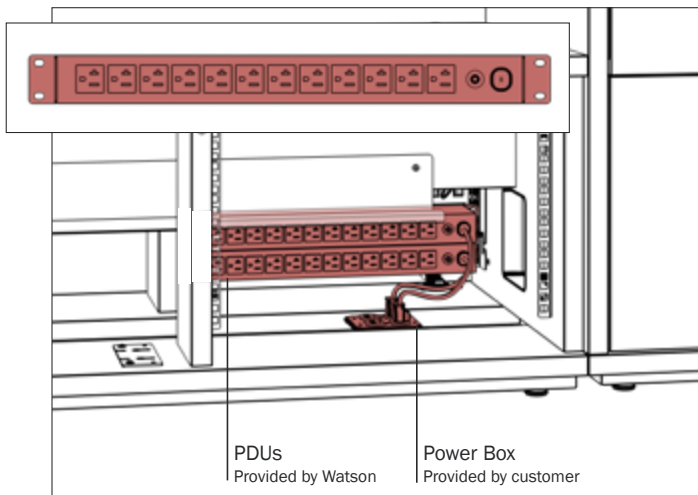

## Network Switches

Network switches (not included) can be installed two ways:

- A. Mount junction boxes to inside of inside of hub, cable bridge or technology cabinet (pictured).
- B. Use rack mounted switchboards.

